

GX 12/29 EVO FREE LIFT

FULLY FEATURED COMPACT STACKER



This compact, powerful and robust stacker is the ideal solution for working in confined spaces.

The reduced width (800 mm), the lateral driving system and the wide mast positioning allow great manoeuvrability, stability and visibility.

Built-in battery charger with integrated cable and plug make it a plug and play unit!

GX EVO AGM FREE LIFT

This stacker combines the features of the GX EVO AGM (long life and endurance AGM deep cycle batteries, proportional fork control) and a more ergonomic tiller with the total FREE LIFT, permitting to rise the forks up to 1.492 mm from the ground level without increasing the minimum machine height (1.965 mm).

For this reason the truck can also be used in working spaces with reduced height.



MANOEUVRABILITY

The overall width is the same as the Europallet (800 mm) to allow working in narrow spaces and corridors, increasing manoeuvrability and reducing the turning radius. The combination of side guide, wide mast and low cover offer outstanding visibility.

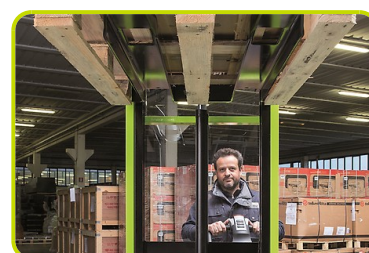

TILLER EVOLUTION

Fully integrated ergonomic technopolymer tiller system including finger tip throttle and proportional fork controls, safety pushbutton, horn, turtle button, hourmeter, battery status indicator as standard equipment.



COVER

Strong ABS cover with storage compartments on top, easily removable to speed up maintenance operations. The bottom access opening enables an immediate disassembly of motor wheel, portal and tiller without lifting the machine. Schuko plug with spiral cable for an easy battery charging.



BATTERY PACK EVO

A separate compartment is the housing of SEMI-TRACTION batteries. Such batteries are powerful (118Ah C5) allowing 3 hours endurance with a lifetime comparable to a real traction battery (1500 recharging cycles). GEL batteries available on demand.



Description

1.1 Manufacturer			PR INDUSTRIAL
1.3 Drive			Electric
1.4 Operator type			Pedestrian
1.5 Load capacity	Q	Kg	1200
1.6 Load centre distance	c	mm	600
1.8 Load axle to end forks	x	mm	780
1.9 Wheel base	y	mm	1234

Weights

2.1 Service weight (battery included)		Kg	615
2.2 Axle load, laden rear		Kg	1187
2.2 Axle load, laden front		Kg	628
2.3 Axle load, unladen front		Kg	453
2.3 Axle load, unladen rear		Kg	162

Tyres/Chassis

3.1 Tyres: front wheels			RUBBER
3.1 Tyres: stabilizers wheels - Front			POLY.C.
3.1 Tyres: rear wheels			POLY.C.
3.2 Tyre size: Steering wheels - Width		mm	76
3.2 Tyre size: Steering wheels - Diameter		mm	250
3.3 Tyre size: Load rollers - Diameter		mm	82
3.3 Tyre size: Load rollers - Width		mm	70
3.4 Tyre size: stabilizers wheels front - Diameter		mm	100
3.4 Tyre size: stabilizers wheels front - Width		mm	38
3.5 Tyre size: rear wheels - Q.ty (X=driven)		nr	2
3.5 Tyre size: front wheels - Q.ty (X=driven)		nr	1x+1
3.6 Tread, front	b10	mm	565
3.7 Tread, rear	b11	mm	410

Dimensions

4.2 Height, mast lowered	h1 mm	1965
4.3 Normal free lifting	h2 mm	1402
4.4 Lift height	h3 mm	2810
4.5 Height, mast extended	h4 mm	3372
4.9 Height of tiller in drive position max	h14 mm	1330
4.9 Height of tiller in drive position min	h14 mm	960
4.15 Height, lowered	h13 mm	90
4.19 Overall length	l1 mm	1760
4.20 Length to face of forks	l2 mm	609
4.21 Overall width	b1 mm	800
4.22 Fork dimensions - Thickness	s mm	70
4.22 Fork dimensions - Width	e mm	150
4.22 Fork dimensions - Length	l mm	1150
4.24 Fork carriage width	b3 mm	650
4.25 Distance between fork arms	b5 mm	560
4.32 Ground clearance, centre of wheelbase	m2 mm	20
4.34 Aisle width	Ast mm	2210
4.35 Turning radius	Wa mm	1430

Performance data

5.1 Travel speed laden	Km/h	4.7
5.1 Travel speed unladen	Km/h	5.2
5.2 Lifting speed laden	m/s	0.10
5.2 Lifting speed unladen	m/s	0.18
5.3 Lowering speed laden	m/s	0.20
5.3 Lowering speed unladen	m/s	0.22
5.8 Max gradeability laden	%	5
5.8 Max gradeability unladen	%	10
5.10 Service brake		Electric

Electric motors

6.1 Drive motor power	kW	0.7
6.2 Lift motor power	kW	2.2
Battery Type	Tipo	Traction (C5)
6.4 Battery voltage	V	24
6.4 Battery capacity, Min	Ah	118
6.4 Battery capacity, Max	Ah	118
6.5 Battery weight, Min	Kg	34
6.5 Battery weight, Max	Kg	100
6.6 Energy consumption according to VDI cycle	kWh/h	0.9
8.4 Sound level at driver's ear	dB(A)	62

Residual lifting capacity

Lifting height (H3) 2500 mm	Kg	1200
Lifting height (H3) 2900 mm	Kg	800

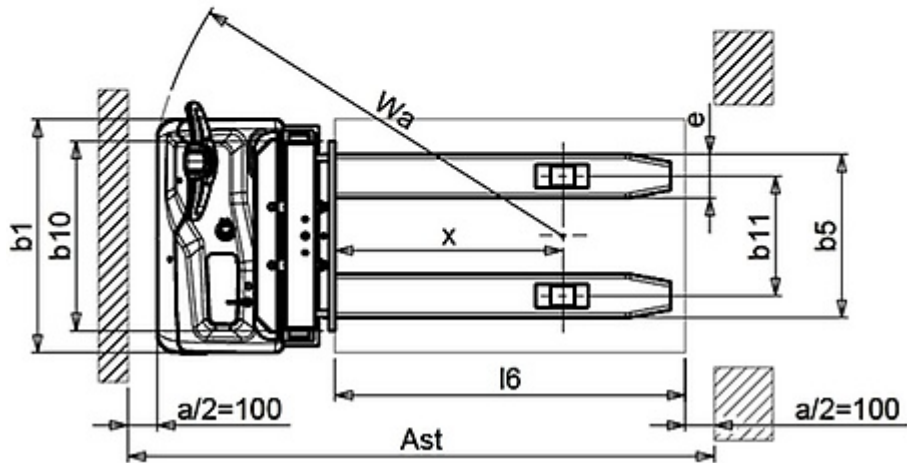
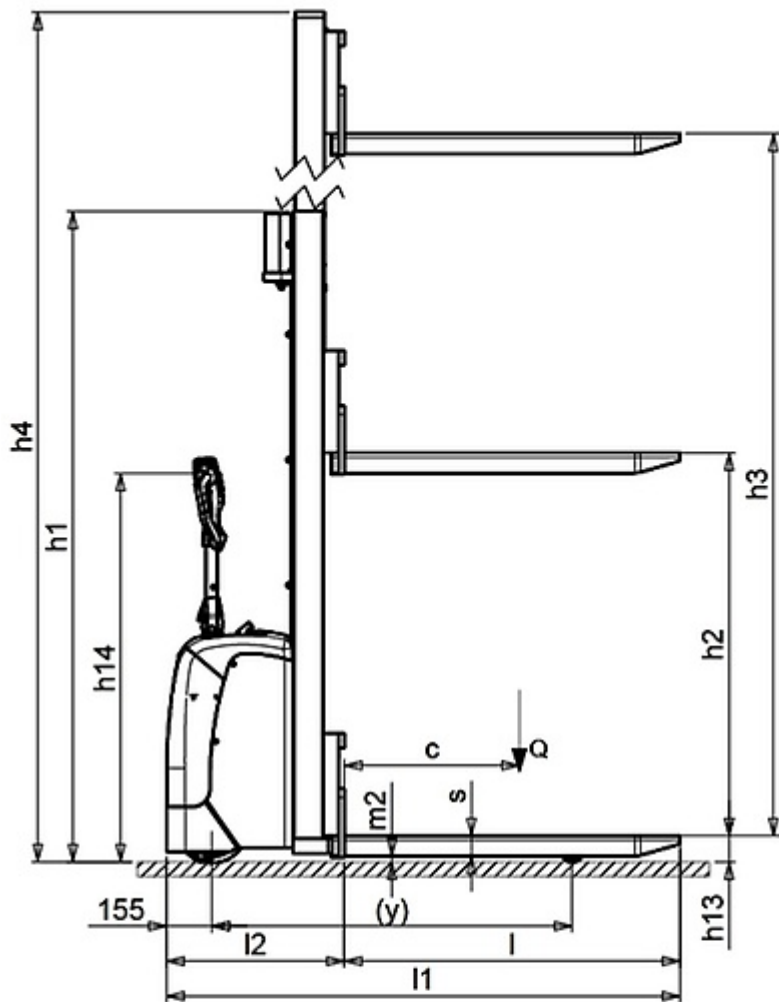

The information is aligned with the Data file at the time of download. Printed on 29/04/2019 (ID 4279)

©2019 | PR INDUSTRIAL s.r.l. | All rights reserved | Image shown may not reflect actual package. Specifications subject to change without notice

